

Technical Data Sheet for Polypropylene Filler Un twisted-1-016

1- Application:-

Polypropylene yarn filler, Un twisted, color white, for filling of multi-core power cables. The yarn shall be of equal composition, no lumps or thin spots or other irregularities.

- Number of denier to be specified in the order confirmation.

2- Sizes & MC Properties:-

Technical Data	Polypropylene Filler Un Twisted							
Denier	15,000	24,000	36,000	45,000	75,000	85,000	100,000	125,000
Weight gr./ Meter	1.66	2.66	4.0	5.0	8.3	9.44	11.11	13.88
Breaking load kgf	6-10	12-16	30- 35	40-45	50-54	57-60	62-65	66-70
Elongation	15-20	15-20	15-20	15-20	15-20	15-20	15-20	15-20
Tolerance	± 5%	± 5%	± 5%	± 5%	± 5%	± 5%	± 5%	± 5%

Technical Data	Polypropylene Filler Un Twisted						
Denier	150,000	200,000	250,000	300,000	360,000	400,000	450,000
Weight gr./ Meter	16.66	22.22	27.8	33.3	40.0	44.4	50.00
Breaking load kgf	72-76	95-100	120-130	150-165	170-180	185-195	210-240
Elongation	15-20	15-20	15-20	15-20	15-20	± 5%	15-20
Tolerance	± 5%	± 5%	± 5%	± 5%	± 5%	± 5%	± 5%

- Fillers are adequate tensile strength and elongation such that no cracks or damage may occur during the processing.

Values of tensile and elongation are expressed in the above table.

3- General Properties:-

- PP Filler is compatible with XLPE, PVC and Copper.
- Maximum continuous operating temperature is 105 C and suitable for a maximum conductor temperature of 90 C .
- Average acceptable specific weight is $1.30 \text{ g/cm}^3 \pm 10\%$ unless it is agreed before ordering.
- Average acceptable shrinkage is less than $19\% \pm 10\%$ unless it is agreed before ordering

4- Packing and Marking:-

- Polypropylene filler Reels from size 15000 Denier to 450000 Denier have maximum outer diameter 410 mm, inner diameter 76 mm and maximum height 400 mm.
- Reels put on strong wood pallets such that no kind of damage may occur during

transportation, handling and storage.

- On each palette we put a tag including the supplier name, OPF Number, palette Number, filler size, net weight and gross weight.

Packing description:

Net Weight : 30 Kg \pm 10% (each reels)

Dimensions: ID: 76 mm
Length: 400 mm
OD: 410 mm

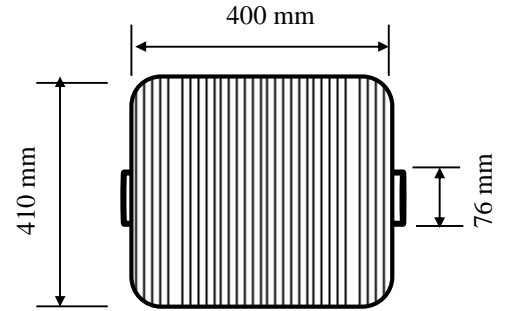

- Packing on pallets and rapped with stretch tape.

2. Conditioning:

- PP filler reels put on pallets and covered with shrinkable film.
- Different approved types of packing to be stated in order confirmation.

Technical Data Sheet for Polypropylene Filler Twisted-1/016

- Application:-

Polypropylene yarn filler, twisted, color white, for filling of multi-core power cables. The yarn shall be of equal composition, no lumps or thin spots or other irregularities.

- Number of denier to be specified in the order confirmation.

- Sizes & MC Properties:-

Technical Data	Polypropylene Filler Twisted							
Filler Size mm	1.5	2.2	3.0	3.3	4.2	4.5	5.0	5.5
Weight gr. / Meter	1.66	2.66	4.0	5.0	8.3	9.44	11.11	13.88
Breaking load kgf	6-10	12-16	30-35	40-45	50-54	57-60	62-65	66-70
Elongation	15-20	15-20	15-20	15-20	15-20	15-20	15-20	15-20
Tolerance	± 5%	± 5%	± 5%	± 5%	± 5%	± 5%	± 5%	± 5%

Technical Data	Polypropylene Filler Twisted						
Filler Size mm	6.0	7.0	8.0	8.66	9.5	10.0	10.6
Weight gr. / Meter	16.66	22.22	27.8	33.3	40.0	44.44	50.00
Breaking load kgf	72-76	95-100	120-130	150-165	170-180	185-195	210-240
Elongation	15-20	15-20	15-20	15-20	15-20	15-20	15-20
Tolerance	± 5%	± 5%	± 5%	± 5%	± 5%	± 5%	± 5%

- Packing and Marking:-

- Polypropylene filler coils from size 1.5mm to 6 mm have maximum outer diameter 210 mm, inner diameter 50 mm and maximum height 300 mm.
- Polypropylene filler coils from size 7mm to 10.6 mm have maximum outer diameter 410 mm, inner diameter 76 mm and maximum height 400 mm.
- Coils put on strong wood pallets such that no kind of damage may occur during transportation, handling and storage.
- On each palette we put a tag including the supplier name, OPF Number, palette Number, filler size, net weight and gross weight.

Packing description up to 6 mm size:

Weight : 10 Kg \pm 5% (each reel)

Dimensions: ID: 50 mm
Length: 300 mm
OD: 210 mm

- Packing on ballets and raped with stretch tape.

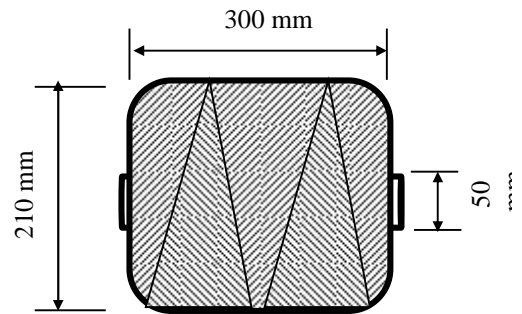
**Packing description from 6.5mm to 10.6 mm size:**

Weight : 30 Kg \pm 5% (each reel)

Dimensions : ID: 76 mm
Length: 400 mm
OD: 410 mm

- Packing on ballets and raped with stretch tape.

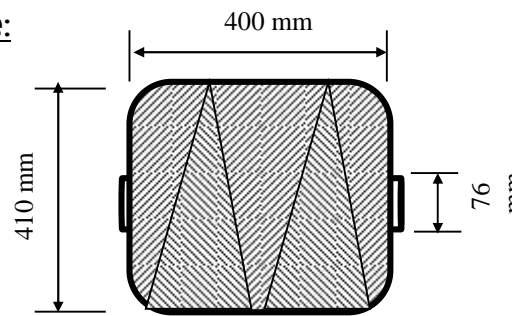
**- Conditioning:**

- PP filler reels put on pallets and covered with shrinkable film.
- Different approved types of packing to be stated in order confirmation.

